



ASSEMBLY INSTRUCTIONS

MODEL: 11485 T

DESCRIPTION: Springfield Table

Thank you for purchasing this quality product from F.A.M.E. Industries. Place all parts on a clean and smooth surface such as a rug or carpet to avoid the parts from being scratched. Be sure to check all packed material carefully for small parts which may have come loose inside the carton during shipment. In the event that you find any hardware missing (screws, dowels, buttons), please call our customer service at 1-877-Go 4 FAME. We will promptly ship you via overnight mail the missing hardware. We hope you find our product "Simply- Simple to assemble and welcome your comments to MyFAMEexperience@simply-simple123.com

NOTE: DURING ASSEMBLY, DO NOT TIGHTEN ANY HARDWARE UNTIL THE COMPLETE UNIT HAS BEEN ASSEMBLED.

HARDWARE & PARTS LIST

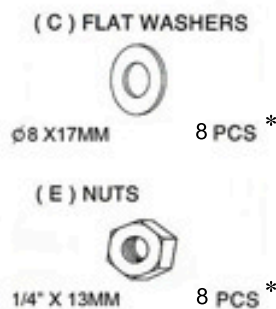
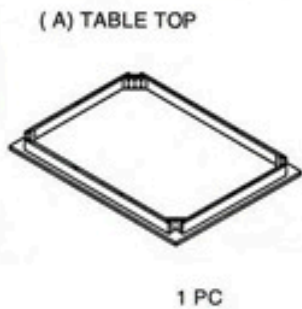

* 1PC EXTRA HARDWARE INCLUDED

STEP 1: Lay the table top (A) upside down on a carpet or other soft, non-marring surface.

STEP 2: Insert leg (B) into each corner. Place a flat washer (C), spring washer (D) and nut (E) onto each leg bolt and tighten the nut using the key wrench (F). Check to make sure each leg is fully tightened.

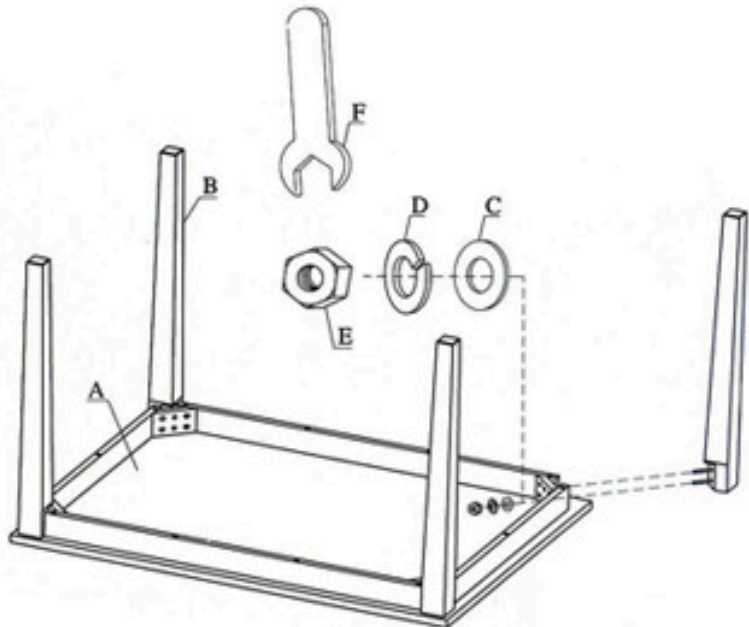

PLEASE NOTE IT MAY REQUIRE 2 PEOPLE TO TURN THE TABLE UPRIGHT.